

Operating Temperature: 0°C~70°C
 Operating Humidity: 20%~80% (no condensation)
 Storage Temperature: -25°C~85°C
 Storage Humidity: 20%~80% (no condensation)

L:
 CBL-PD302MB-1m 1000mm±10mm
 CBL-PD302MB-2m 2000mm±20mm
 CBL-PD302MB-3m 3000mm±20mm

No	MATERIALS LIST:
1.	CABLE:UL2725 (28AWG*1PR+D+AM)x2C+28AWG*1PR+24AWG*1C+AM+B OD:5.6mm PVC JACKET COLOR:BLACK
2.	CONNECTOR:USB 3.0 A/M, 9P, BLUE INSULATOR SOLDER TYPE, NICKEL PLATED SHELL
3.	CONNECTOR:USB 3.0 MicroB/M, 10P, BLACK INSULATOR SOLDER TYPE, NICKEL PLATED SHELL
4.	PVC MOLDED HOUSING, BLACK COLOR

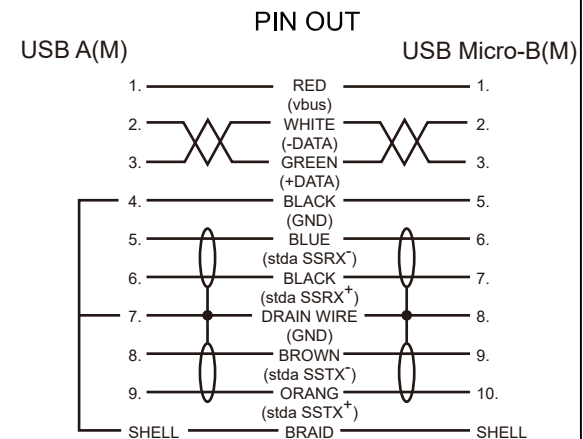

Jargy part no.	Client part no.	Approved	SCALE	UNIT
CBL-PD302MB-Xm				mm
Drawing Name		Drawn	Date	REV.
USB 3.0 A to MicroB Cable M/M				1.0



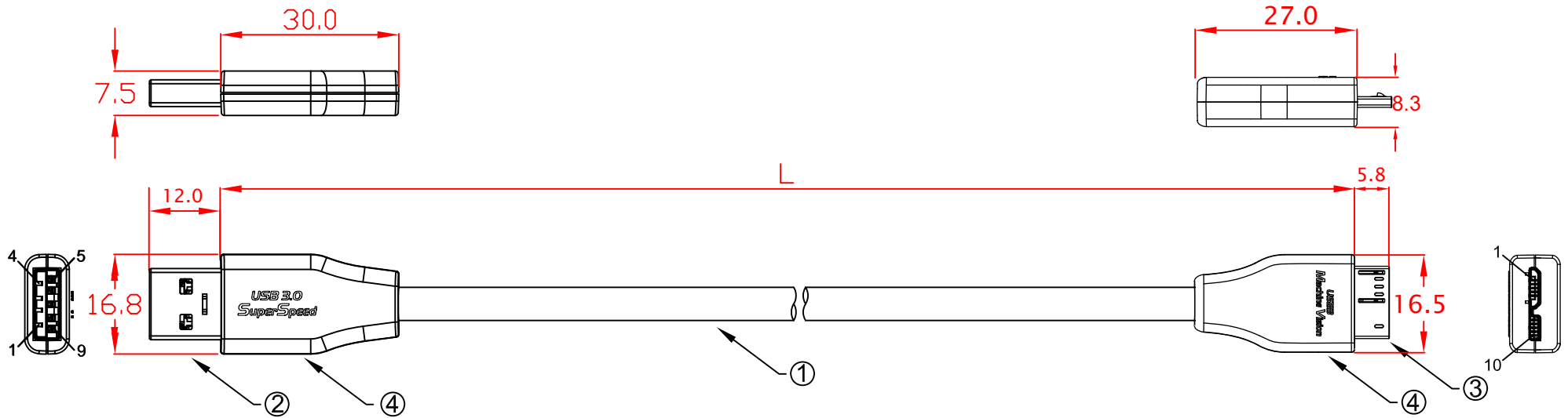

Operating Temperature: 0°C~70°C
 Operating Humidity: 20%~80% (no condensation)
 Storage Temperature: -25°C~85°C
 Storage Humidity: 20%~80% (no condensation)

L:
 CBL-PD302MB-1m 1000mm±10mm
 CBL-PD302MB-2m 2000mm±20mm
 CBL-PD302MB-3m 3000mm±20mm

No	MATERIALS LIST:
1.	CABLE:UL2725 (28AWG*1PR+D+AM)x2C+28AWG*1PR+24AWG*1C+AM+B OD:5.6mm PVC JACKET COLOR:BLACK
2.	CONNECTOR:USB 3.0 A/M, 9P, BLUE INSULATOR SOLDER TYPE, NICKEL PLATED SHELL
3.	CONNECTOR:USB 3.0 MicroB/M, 10P, BLACK INSULATOR SOLDER TYPE, NICKEL PLATED SHELL
4.	ABS ASSEMBLY HOUSING, BLACK COLOR

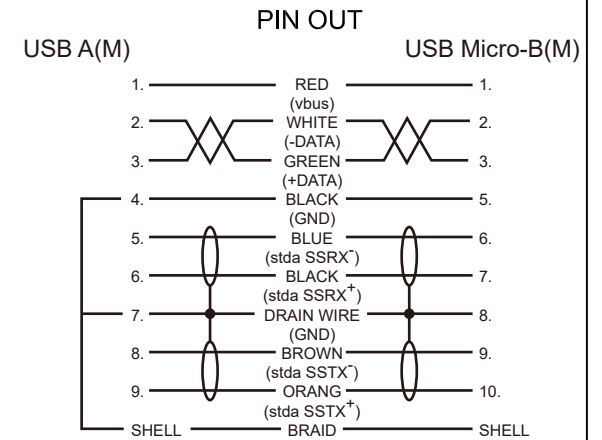

Jargy part no.	Client part no.	Approved	SCALE	UNIT
CBL-PD302MB-Xm				mm
Drawing Name		Drawn	Date	REV.
USB 3.0 A to MicroB Cable M/M				1.0

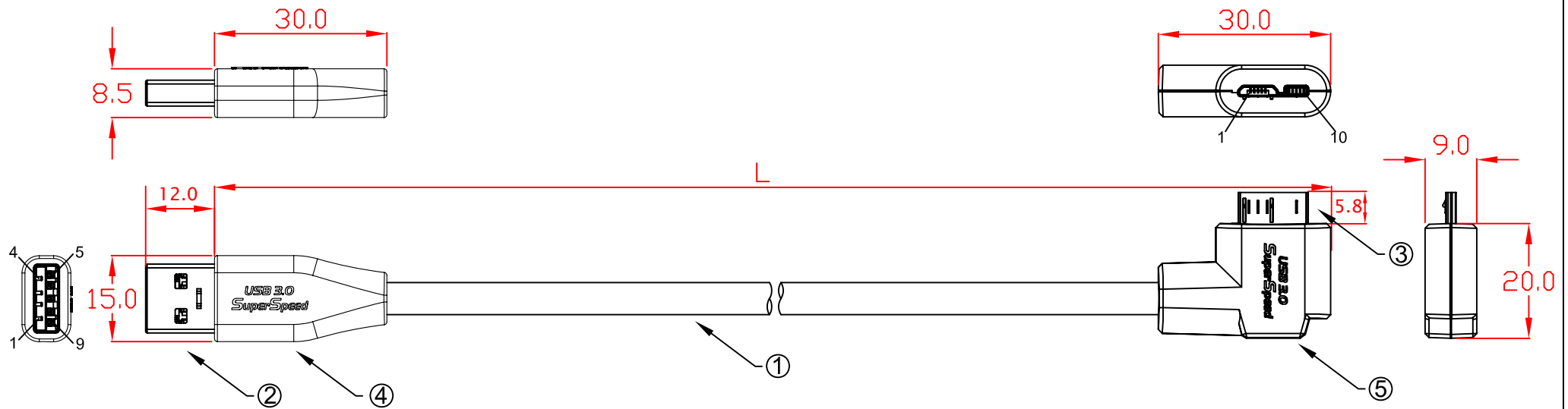

L:
 CBL-PD302MB-1mLA 1000mm±10mm
 CBL-PD302MB-2mLA 2000mm±20mm
 CBL-PD302MB-3mLA 3000mm±20mm

No	MATERIALS LIST:
1.	CABLE:UL2725 (28AWG*1PR+D+AM)x2C+28AWG*1PR+24AWG*1C+AM+B OD:5.6mm PVC JACKET COLOR:BLACK
2.	CONNECTOR:USB 3.0 A/M, 9P, BLUE INSULATOR SOLDER TYPE, NICKEL PLATED SHELL
3.	CONNECTOR:USB 3.0 MicroB/M, 10P, BLACK INSULATOR SOLDER TYPE, NICKEL PLATED SHELL
4.	PVC MOLDED HOUSING, BLACK COLOR
5.	ABS ASSEMBLY HOUSING, BLACK COLOR

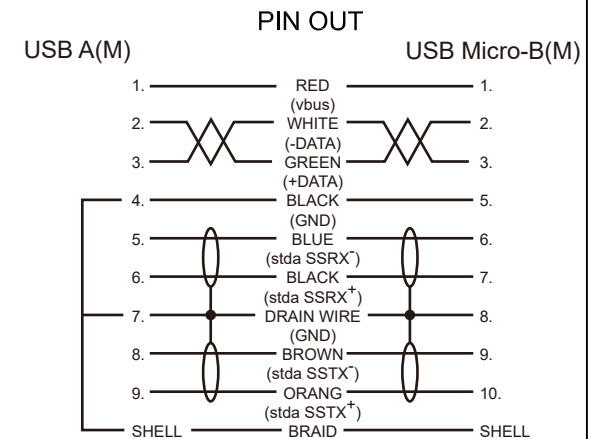

Jargy part no.	Client part no.	Approved	SCALE	UNIT
CBL-PD302MB-XmLA				mm
Drawing Name		Drawn	Date	REV.
USB 3.0 A to MicroB Cable M/M				1.0

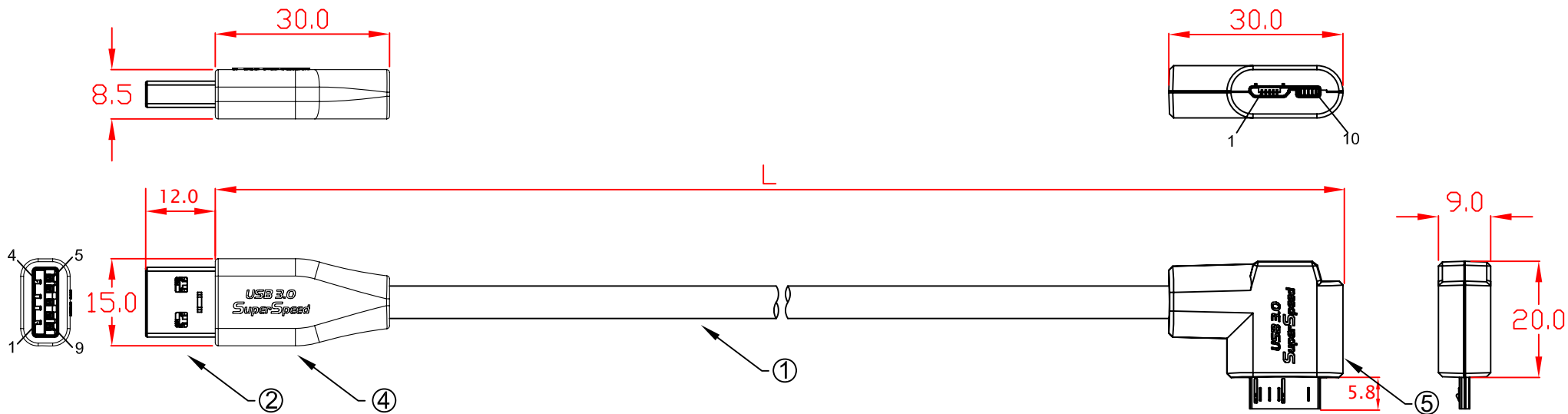

Operating Temperature: 0°C~70°C
 Operating Humidity: 20%~80% (no condensation)
 Storage Temperature: -25°C~85°C
 Storage Humidity: 20%~80% (no condensation)

L:
 CBL-PD302MB-1mRA 1000mm±10mm
 CBL-PD302MB-2mRA 2000mm±20mm
 CBL-PD302MB-3mRA 3000mm±20mm

No	MATERIALS LIST:
1.	CABLE:UL2725 (28AWG*1PR+D+AM)x2C+28AWG*1PR+24AWG*1C+AM+B OD:5.6mm PVC JACKET COLOR:BLACK
2.	CONNECTOR:USB 3.0 A/M, 9P, BLUE INSULATOR SOLDER TYPE, NICKEL PLATED SHELL
3.	CONNECTOR:USB 3.0 MicroB/M, 10P, BLACK INSULATOR SOLDER TYPE, NICKEL PLATED SHELL
4.	PVC MOLDED HOUSING, BLACK COLOR
5.	ABS ASSEMBLY HOUSING, BLACK COLOR

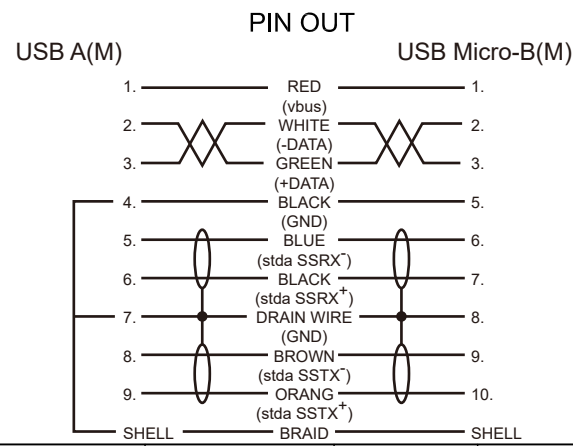

Jargy part no.	Client part no.	Approved	SCALE	UNIT
CBL-PD302MB-XmRA				mm
Drawing Name		Drawn	Date	REV.
USB 3.0 A to MicroB Cable M/M				1.0

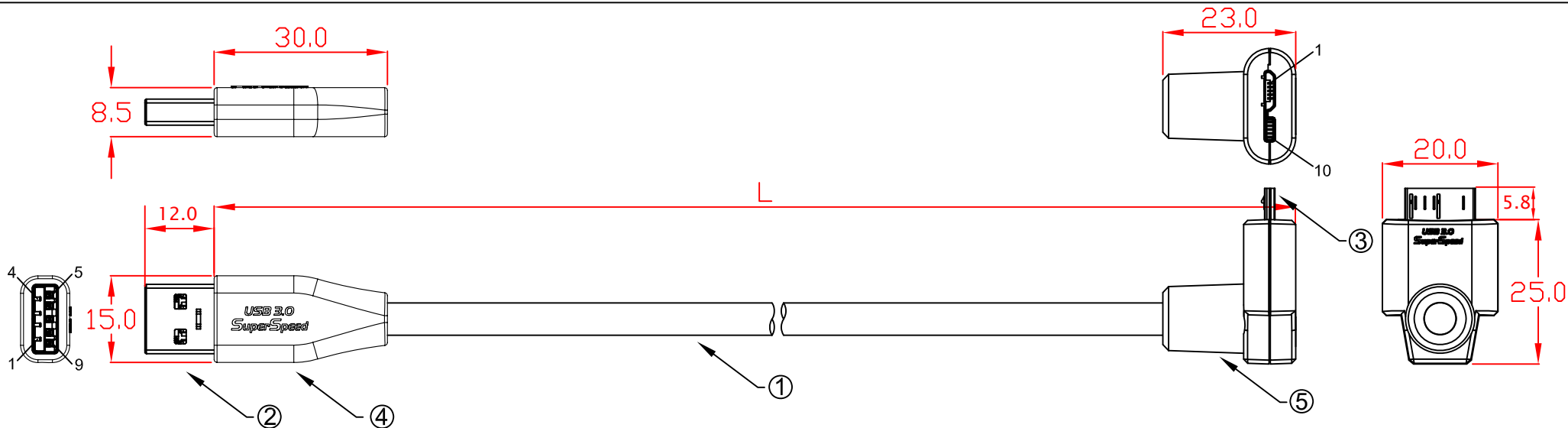

Operating Temperature: 0°C~70°C
 Operating Humidity: 20%~80% (no condensation)
 Storage Temperature: -25°C~85°C
 Storage Humidity: 20%~80% (no condensation)

L:
 CBL-PD302MB-1mUA 1000mm±10mm
 CBL-PD302MB-2mUA 2000mm±20mm
 CBL-PD302MB-3mUA 3000mm±20mm

No	MATERIALS LIST:
1.	CABLE:UL2725 (28AWG*1PR+D+AM)x2C+28AWG*1PR+24AWG*1C+AM+B OD:5.6mm PVC JACKET COLOR:BLACK
2.	CONNECTOR:USB 3.0 A/M, 9P, BLUE INSULATOR SOLDER TYPE, NICKEL PLATED SHELL
3.	CONNECTOR:USB 3.0 MicroB/M, 10P, BLACK INSULATOR SOLDER TYPE, NICKEL PLATED SHELL
4.	PVC MOLDED HOUSING, BLACK COLOR
5.	ABS ASSEMBLY HOUSING, BLACK COLOR

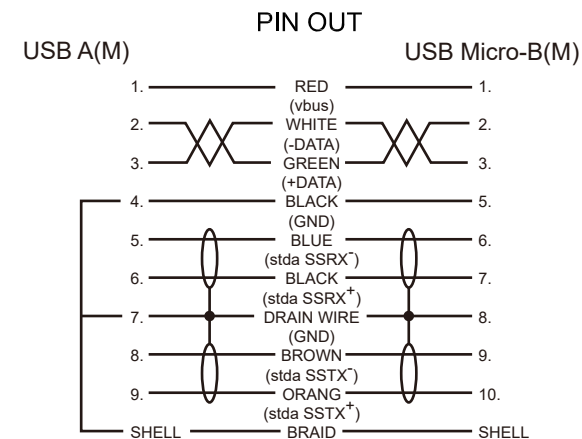

Jargy part no.	Client part no.	Approved	SCALE	UNIT
CBL-PD302MB-XmUA				mm
Drawing Name		Drawn	Date	REV.
USB 3.0 A to MicroB Cable M/M				1.0

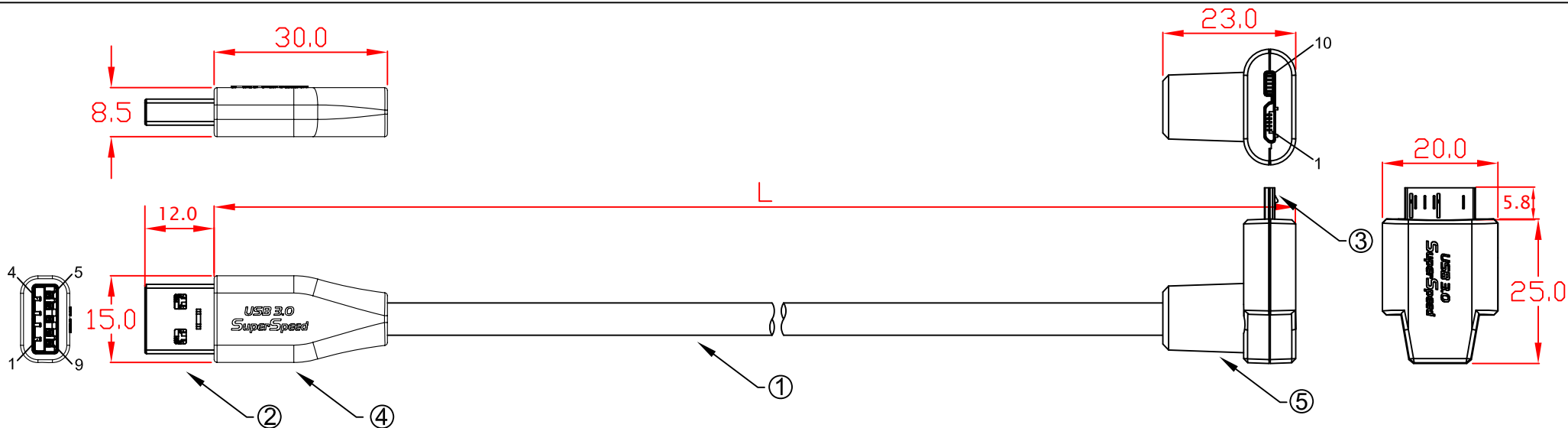

Operating Temperature: 0°C~70°C
 Operating Humidity: 20%~80% (no condensation)
 Storage Temperature: -25°C~85°C
 Storage Humidity: 20%~80% (no condensation)

L:
 CBL-PD302MB-1mDA 1000mm±10mm
 CBL-PD302MB-2mDA 2000mm±20mm
 CBL-PD302MB-3mDA 3000mm±20mm

No	MATERIALS LIST:
1.	CABLE:UL2725 (28AWG*1PR+D+AM)x2C+28AWG*1PR+24AWG*1C+AM+B OD:5.6mm PVC JACKET COLOR:BLACK
2.	CONNECTOR:USB 3.0 A/M, 9P, BLUE INSULATOR SOLDER TYPE, NICKEL PLATED SHELL
3.	CONNECTOR:USB 3.0 MicroB/M, 10P, BLACK INSULATOR SOLDER TYPE, NICKEL PLATED SHELL
4.	PVC MOLDED HOUSING, BLACK COLOR
5.	ABS ASSEMBLY HOUSING, BLACK COLOR

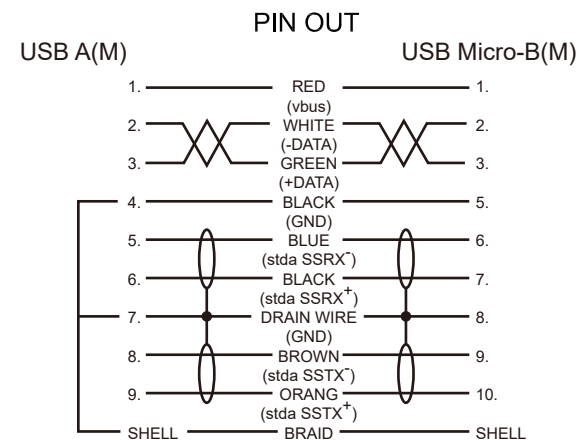

Jargy part no.	Client part no.	Approved	SCALE	UNIT
CBL-PD302MB-XmDA				mm
Drawing Name		Drawn	Date	REV.
USB 3.0 A to MicroB Cable M/M				1.0

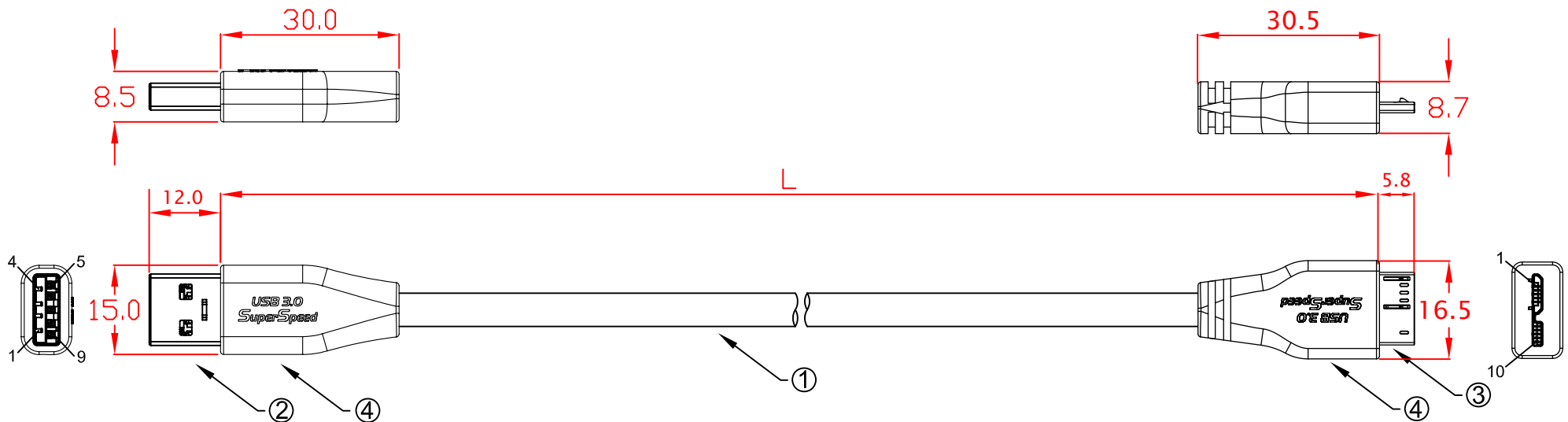

Operating Temperature: 0°C~70°C
 Operating Humidity: 20%~80% (no condensation)
 Storage Temperature: -25°C~85°C
 Storage Humidity: 20%~80% (no condensation)

L:
 CBL-PD302MBWB-4m 4000mm±30mm
 CBL-PD302MBWB-5m 5000mm±30mm
 CBL-PD302MBWB-6m 6000mm±30mm
 CBL-PD302MBWB-7m 7000mm±30mm

No	MATERIALS LIST:
1.	CABLE:UL2725 (28AWG*1PR+D+AM)x2C+28AWG*1PR+24AWG*1C+AM+B OD:5.6mm PVC JACKET COLOR:BLACK
2.	CONNECTOR:USB 3.0 A/M, 9P, BLUE INSULATOR SOLDER TYPE, NICKEL PLATED SHELL
3.	CONNECTOR:USB 3.0 MicroB/M, 10P, BLACK INSULATOR SOLDER TYPE, NICKEL PLATED SHELL
4.	PVC MOLDED HOUSING, BLACK COLOR

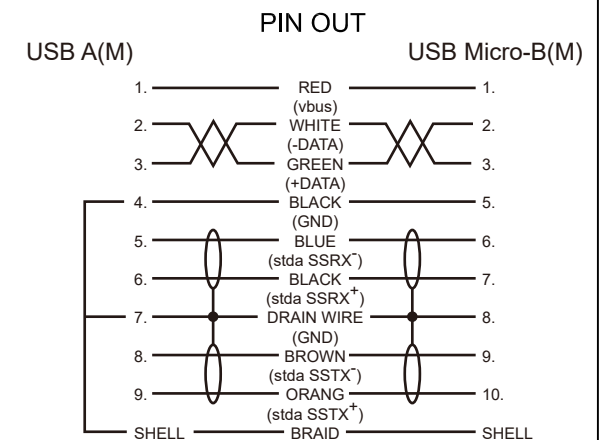

Jargy part no.	Client part no.	Approved	SCALE	UNIT
CBL-PD302MBWB-Xm				mm
Drawing Name		Drawn	Date	REV.
USB 3.0 A to MicroB Cable M/M				1.0

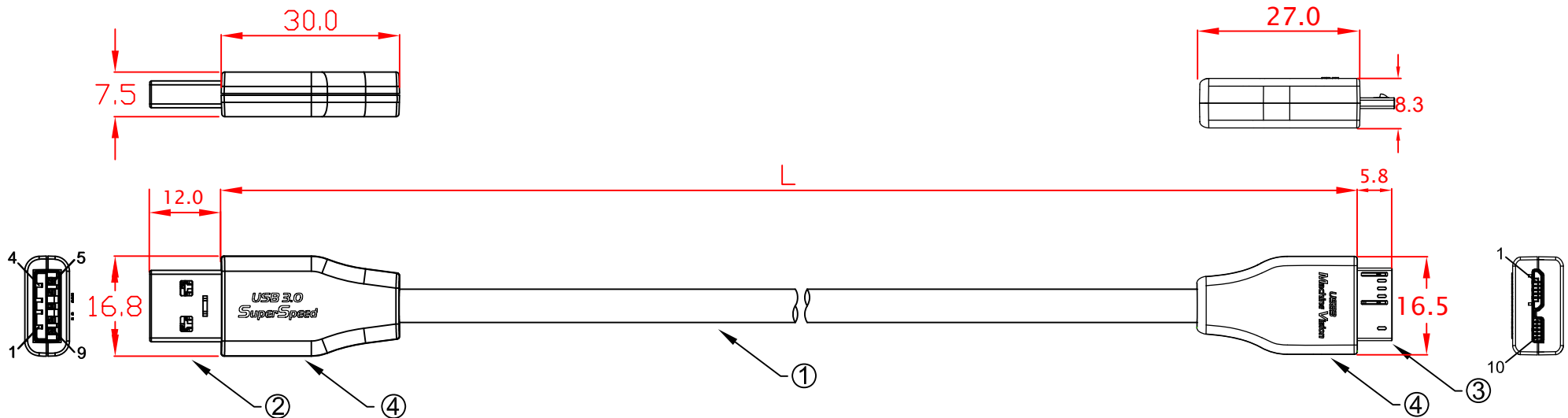

Operating Temperature: 0°C~70°C
 Operating Humidity: 20%~80% (no condensation)
 Storage Temperature: -25°C~85°C
 Storage Humidity: 20%~80% (no condensation)

L:
 CBL-PD302MBWB-4m 4000mm±30mm
 CBL-PD302MBWB-5m 5000mm±30mm
 CBL-PD302MBWB-6m 6000mm±30mm
 CBL-PD302MBWB-7m 7000mm±30mm

No	MATERIALS LIST:
1.	CABLE:UL2725 (28AWG*1PR+D+AM)x2C+28AWG*1PR+24AWG*1C+AM+B OD:5.6mm PVC JACKET COLOR:BLACK
2.	CONNECTOR:USB 3.0 A/M, 9P, BLUE INSULATOR SOLDER TYPE, NICKEL PLATED SHELL
3.	CONNECTOR:USB 3.0 MicroB/M, 10P, BLACK INSULATOR SOLDER TYPE, NICKEL PLATED SHELL
4.	ABS ASSEMBLY HOUSING, BLACK COLOR

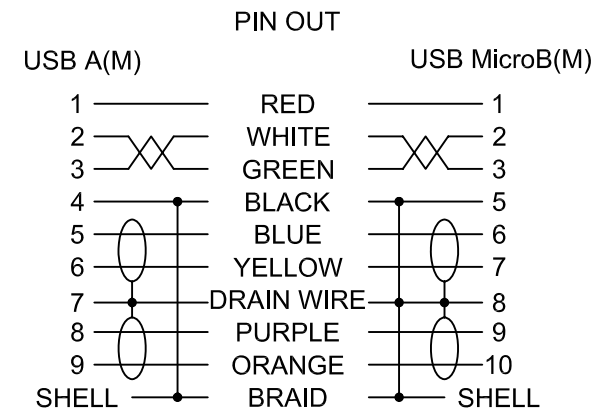

Jargy part no.	Client part no.	Approved	SCALE	UNIT
CBL-PD302MBWB-Xm				mm
Drawing Name		Drawn	Date	REV.
USB 3.0 A to MicroB Cable M/M				1.0

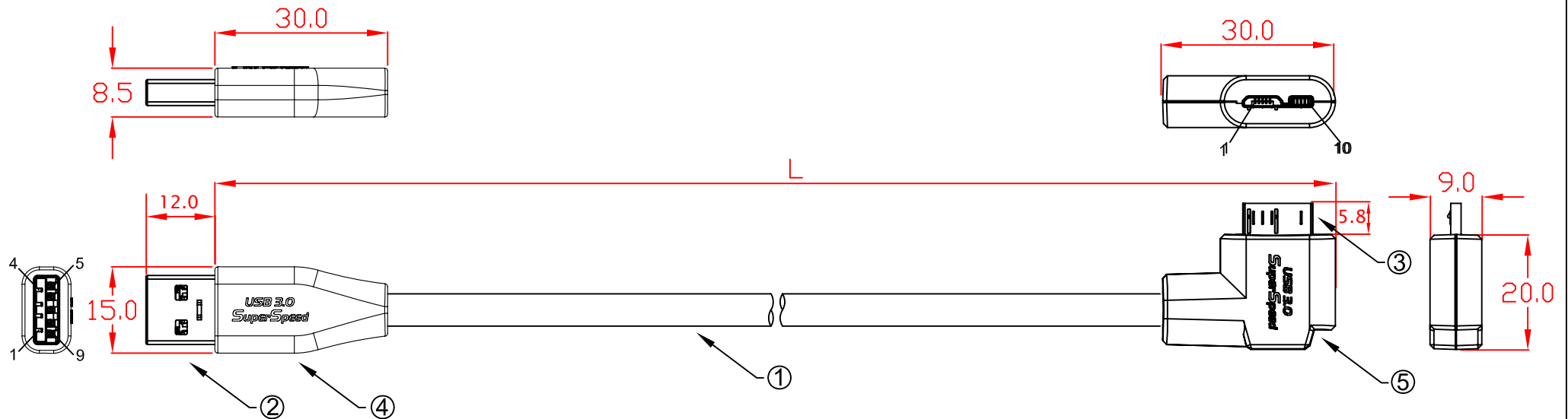

Operating Temperature: 0°C~70°C
 Operating Humidity: 20%~80% (no condensation)
 Storage Temperature: -25°C~85°C
 Storage Humidity: 20%~80% (no condensation)

L:
 CBL-PD302MBWB-4mLA 4000mm±30mm
 CBL-PD302MBWB-5mLA 5000mm±30mm
 CBL-PD302MBWB-6mLA 6000mm±30mm
 CBL-PD302MBWB-7mLA 7000mm±30mm

No	MATERIALS LIST:
1.	CABLE:UL2725 (28AWG*1PR+D+AM)x2C+28AWG*1PR+24AWG*1C+AM+B OD:5.6mm PVC JACKET COLOR:BLACK
2.	CONNECTOR:USB 3.0 A/M, 9P, BLUE INSULATOR SOLDER TYPE, NICKEL PLATED SHELL
3.	CONNECTOR:USB 3.0 MicroB/M, 10P, BLACK INSULATOR SOLDER TYPE, NICKEL PLATED SHELL
4.	PVC MOLDED HOUSING, BLACK COLOR
5.	ABS ASSEMBLY HOUSING, BLACK COLOR

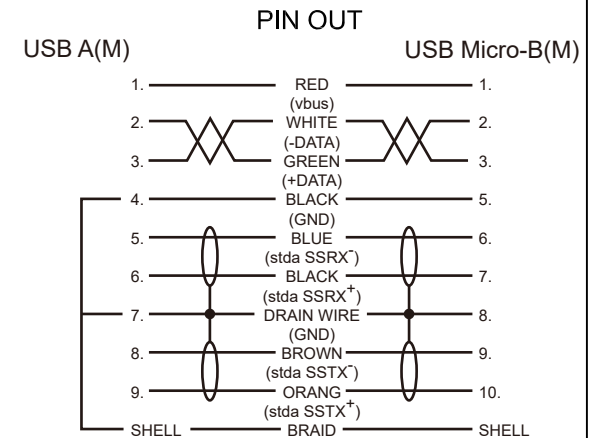

Jargy part no.	Client part no.	Approved	SCALE	UNIT
CBL-PD302MBWB-XmLA				mm
Drawing Name		Drawn	Date	REV.
USB 3.0 A to MicroB Cable M/M				1.0

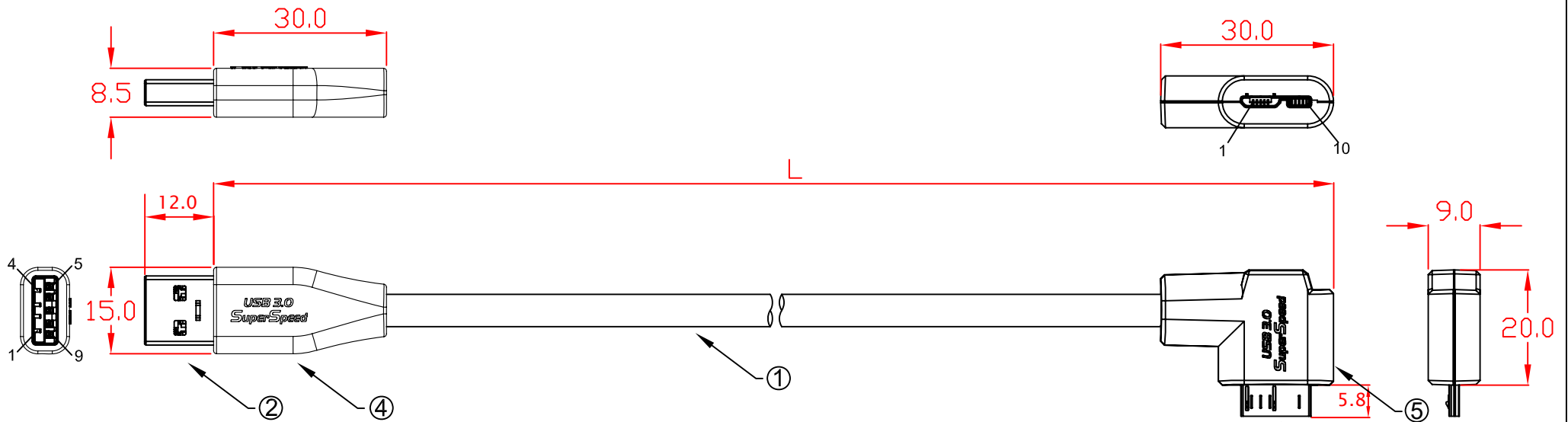

Operating Temperature: 0°C~70°C
 Operating Humidity: 20%~80% (no condensation)
 Storage Temperature: -25°C~85°C
 Storage Humidity: 20%~80% (no condensation)

L:
 CBL-PD302MBWB-4mRA 4000mm±30mm
 CBL-PD302MBWB-5mRA 5000mm±30mm
 CBL-PD302MBWB-6mRA 6000mm±30mm
 CBL-PD302MBWB-7mRA 7000mm±30mm

No	MATERIALS LIST:
1.	CABLE:UL2725 (28AWG*1PR+D+AM)x2C+28AWG*1PR+24AWG*1C+AM+B OD:5.6mm PVC JACKET COLOR:BLACK
2.	CONNECTOR:USB 3.0 A/M, 9P, BLUE INSULATOR SOLDER TYPE, NICKEL PLATED SHELL
3.	CONNECTOR:USB 3.0 MicroB/M, 10P, BLACK INSULATOR SOLDER TYPE, NICKEL PLATED SHELL
4.	PVC MOLDED HOUSING, BLACK COLOR
5.	ABS ASSEMBLY HOUSING, BLACK COLOR

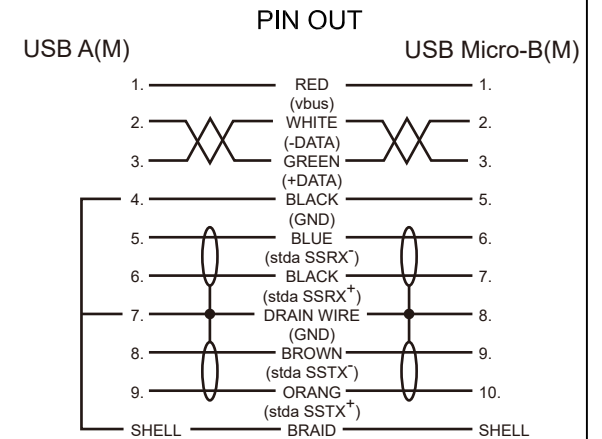

Jargy part no.	Client part no.	Approved	SCALE	UNIT
CBL-PD302MBWB-XmRA				mm
Drawing Name		Drawn	Date	REV.
USB 3.0 A to MicroB Cable M/M				1.0

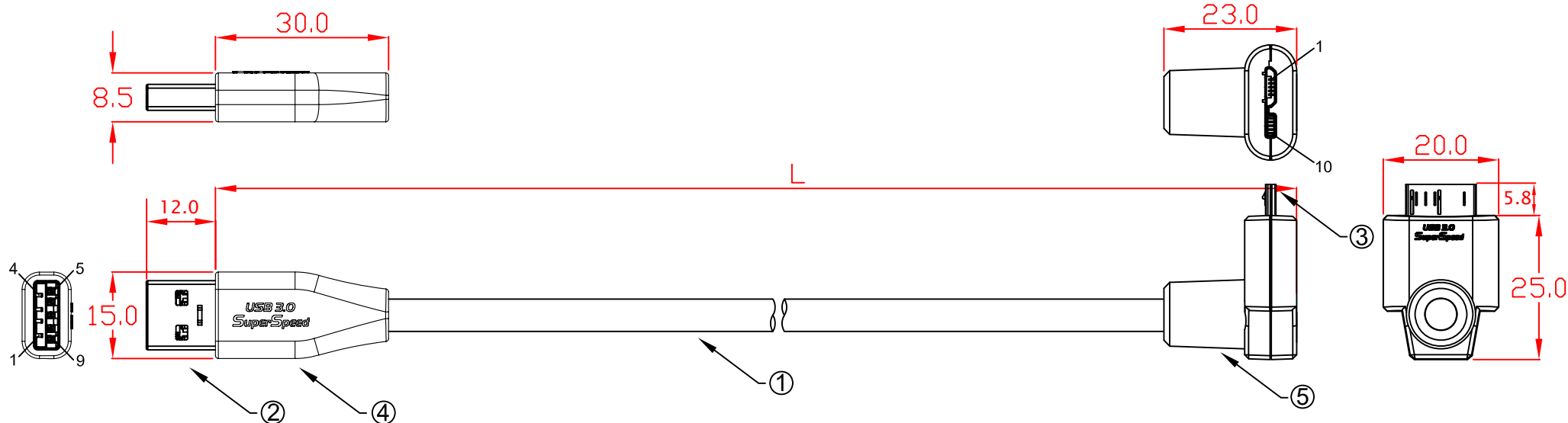

Operating Temperature: 0°C~70°C
 Operating Humidity: 20%~80% (no condensation)
 Storage Temperature: -25°C~85°C
 Storage Humidity: 20%~80% (no condensation)

L:
 CBL-PD302MBWB-4mUA 4000mm±30mm
 CBL-PD302MBWB-5mUA 5000mm±30mm
 CBL-PD302MBWB-6mUA 6000mm±30mm
 CBL-PD302MBWB-7mUA 7000mm±30mm

No	MATERIALS LIST:
1.	CABLE:UL2725 (28AWG*1PR+D+AM)x2C+28AWG*1PR+24AWG*1C+AM+B OD:5.6mm PVC JACKET COLOR:BLACK
2.	CONNECTOR:USB 3.0 A/M, 9P, BLUE INSULATOR SOLDER TYPE, NICKEL PLATED SHELL
3.	CONNECTOR:USB 3.0 MicroB/M, 10P, BLACK INSULATOR SOLDER TYPE, NICKEL PLATED SHELL
4.	PVC MOLDED HOUSING, BLACK COLOR
5.	ABS ASSEMBLY HOUSING, BLACK COLOR

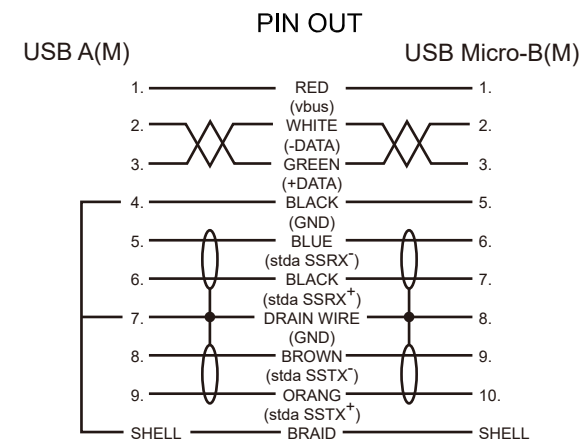

Jargy part no.	Client part no.	Approved	SCALE	UNIT
CBL-PD302MBWB-XmUA				mm
Drawing Name		Drawn	Date	REV.
USB 3.0 A to MicroB Cable M/M				1.0

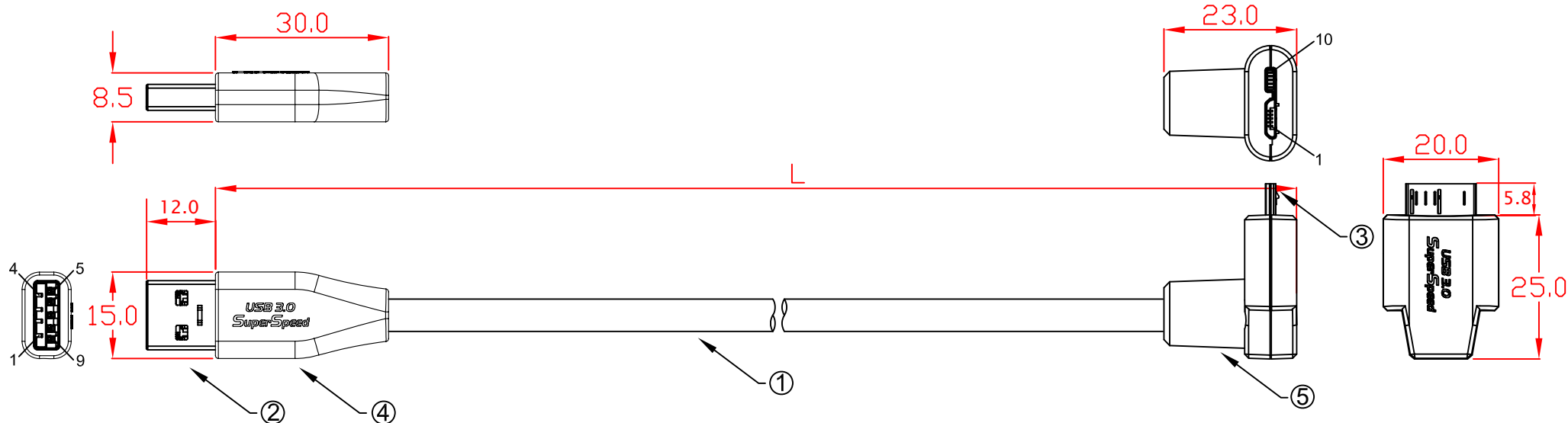

Operating Temperature: 0°C~70°C
 Operating Humidity: 20%~80% (no condensation)
 Storage Temperature: -25°C~85°C
 Storage Humidity: 20%~80% (no condensation)

L:
 CBL-PD302MBWB-4mDA 4000mm±30mm
 CBL-PD302MBWB-5mDA 5000mm±30mm
 CBL-PD302MBWB-6mDA 6000mm±30mm
 CBL-PD302MBWB-7mDA 7000mm±30mm

No	MATERIALS LIST:
1.	CABLE:UL2725 (28AWG*1PR+D+AM)x2C+28AWG*1PR+24AWG*1C+AM+B OD:5.6mm PVC JACKET COLOR:BLACK
2.	CONNECTOR:USB 3.0 A/M, 9P, BLUE INSULATOR SOLDER TYPE, NICKEL PLATED SHELL
3.	CONNECTOR:USB 3.0 MicroB/M, 10P, BLACK INSULATOR SOLDER TYPE, NICKEL PLATED SHELL
4.	PVC MOLDED HOUSING, BLACK COLOR
5.	ABS ASSEMBLY HOUSING, BLACK COLOR

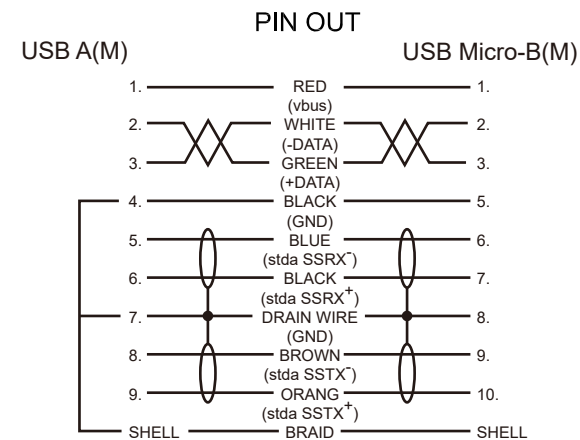

Jargy part no.	Client part no.	Approved	SCALE	UNIT
CBL-PD302MBWB-XmDA				mm
Drawing Name		Drawn	Date	REV.
USB 3.0 A to MicroB Cable M/M				1.0